











- (N) WALL
- (E) WALL
- (N) SMOKE DETECTOR WITH BATTERY BACKUP
- (N) CARBON MONOXIDE DETECTOR
- (N) ELECTRIC WATER HEATER
- 50 CFM TO EXHAUST MOISTURE OF THE BUILDING MECHANICAL VENTILATION REQUIRED IN ALL BATHROOM WITH TUB OR SHOWER
- 100 CFM TO EXHAUST MOISTURE OF THE BUILDING MECHANICAL VENTILATION REQUIRED IN THE KITCHEN  
NOTE: SHALL BE PROVIDED WITH OCCUPANCY SENSORS OR HUMIDITY SENSORS TO AUTOMATICALLY OVERRIDE THE FAN TO THE HIGH SPEED AIRFLOW RATE.
- (N) DUCTLESS SPLIT SYSTEM HEAT PUMP  
MANUFACTURE: BLUERIDGE  
MODEL: BM27M22C-9W-9W-9W  
HEAT FLOOR AREA CALCULATION: 500.00 Sq. Ft.  
HSPF: 10.0  
MAXIMUM COOLING OUTPUT: 27000 BTU  
MAXIMUM HEATING OUTPUT: 28000BTU  
OR SIMILAR IN PRICE AND SPECS  
  
NOTE: THE WHOLE HOUSE VENTILATION WOULD NEED TO HAVE MANUAL OVERRIDE CONTROLS.

NOTE:  
-INSULATION FOR THE NEW PROPOSED INTERIOR AND EXTERIORS WALLS R-21  
-INSULATION FOR THE SLAB ON GRADE R-10 (2' PERIMETER ON THE OUTSIDE OF THE BUILDING)  
-INSULATION FOR CEILING AND SINGLE RAFTER OR JOIST R-49 ADVANCE.

DOOR SCHEDULE				
CODE	QUAN	SIZE	MATERIAL	
D-1	1	3'-0" X 6'-8"	HOLLOW CORE DUO	
D-2	4	2'-8" X 6'-8"	POCKET DOOR	
WINDOW SCHEDULE				
CODE	QUAN	SIZE	MATERIAL	NOTES
W-1	2	5'-0" X 4'-0"	(N) SLIDING VINYL WINDOW	EGRESS WINDOW
W-2	2	3'-0" X 5'-0"	(N) HUNG VINYL WINDOW	
W-3	1	4'-0" X 3'-0"	(N) SLIDING VINYL WINDOW	
W-4	1	2'-0" X 2'-0"	(N) SLIDING VINYL WINDOW	TEMPERED GLASS

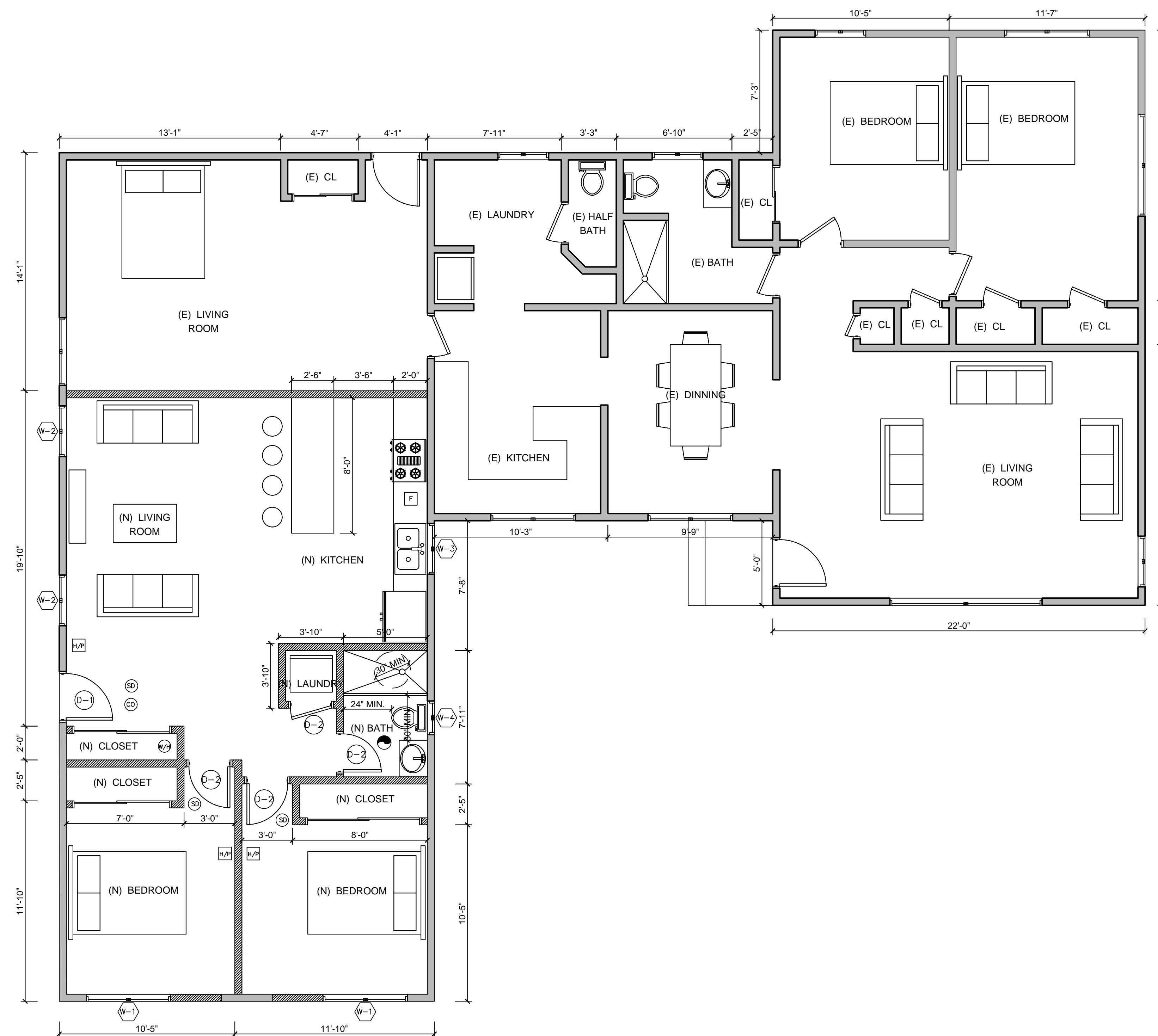

**1** PROPOSED FLOOR PLAN  
SC: 1/4" = 1'

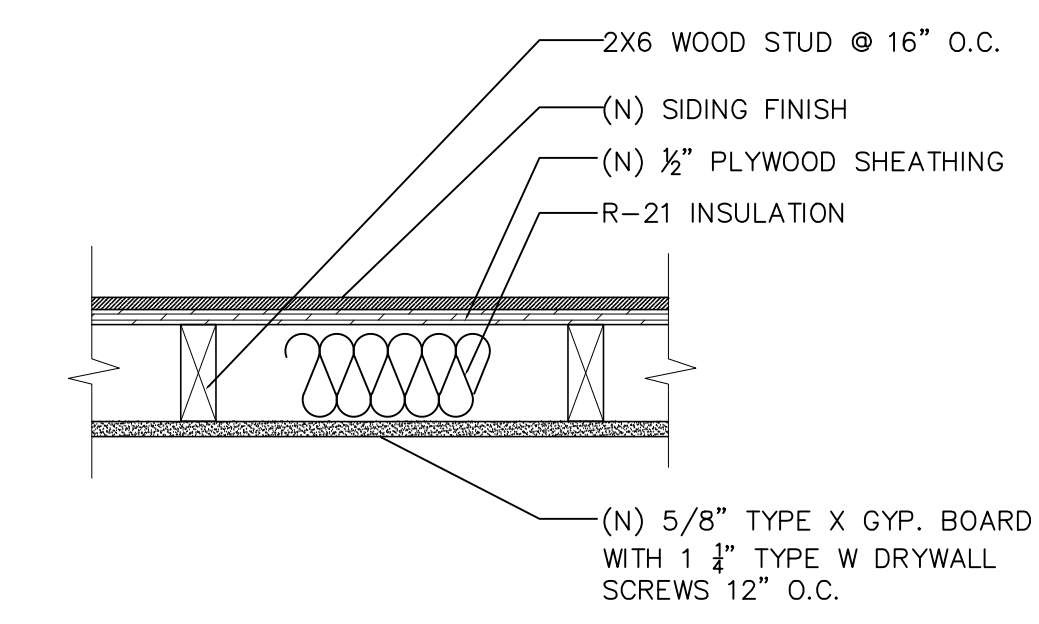

**2** EXTERIOR WALLS TYP.  
NOISE REDUCTION

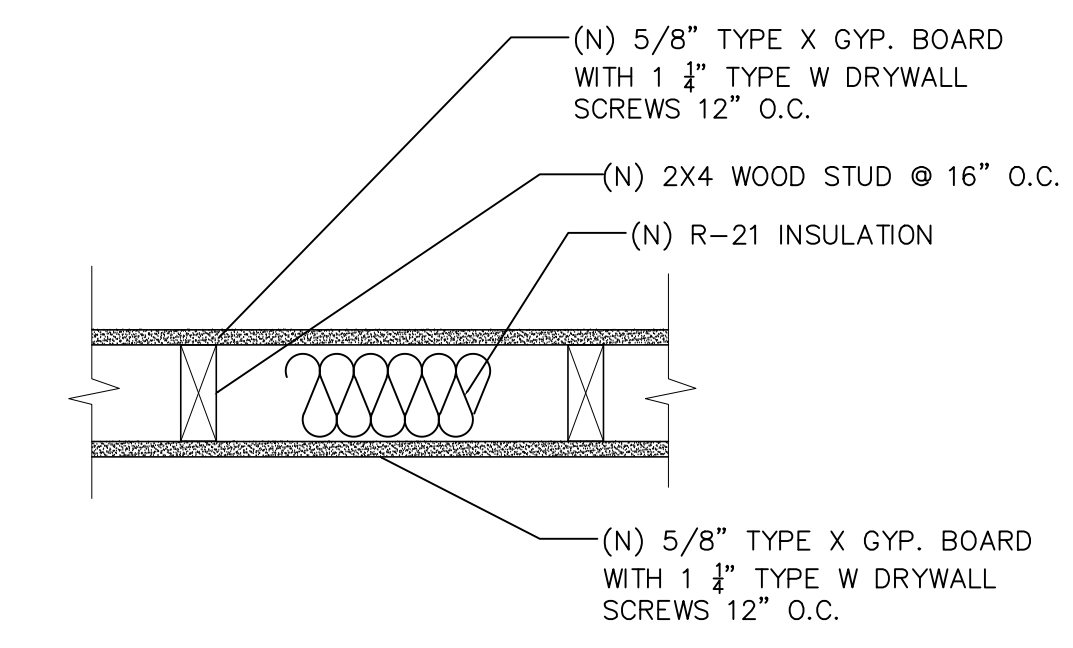

**3** INTERIOR WALLS TYP.  
NOISE REDUCTION

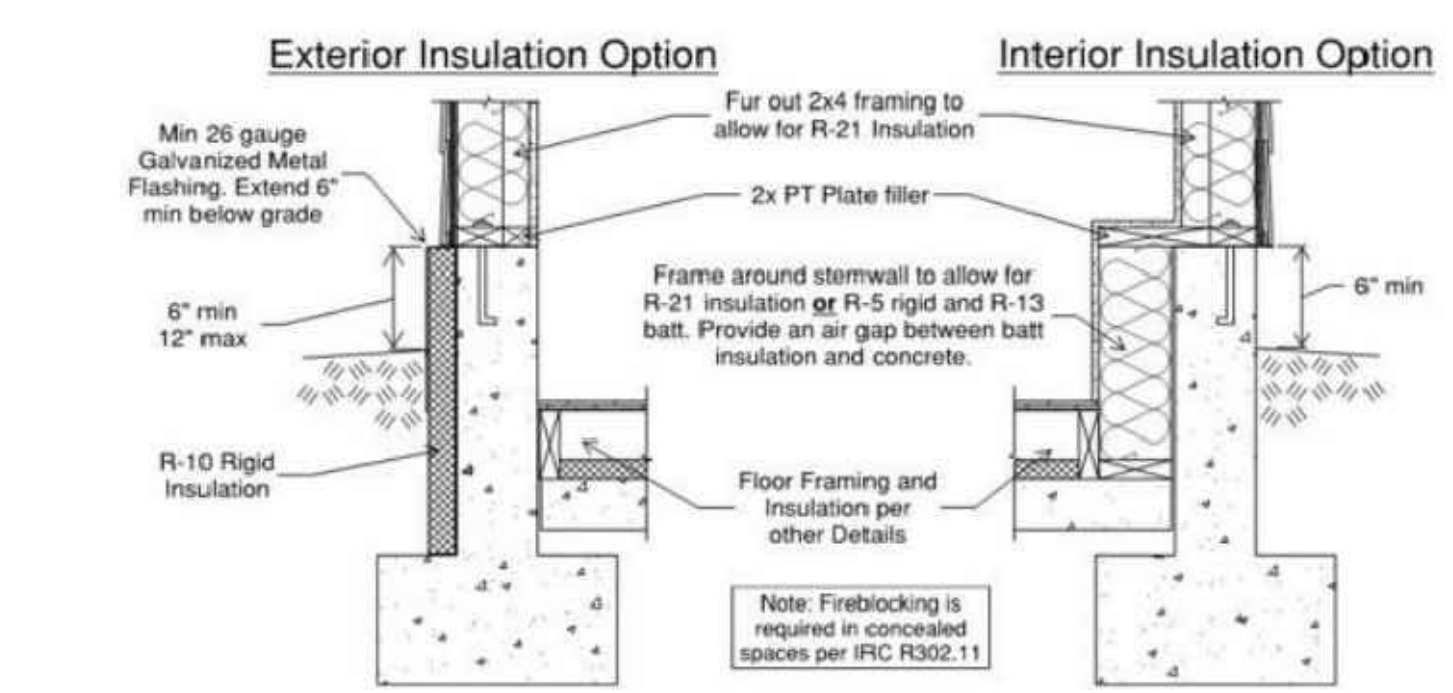

**4** TYP SHEET DETAILS  
FOUNDATION AND FRAMED WALL INSULATION OPTIONS

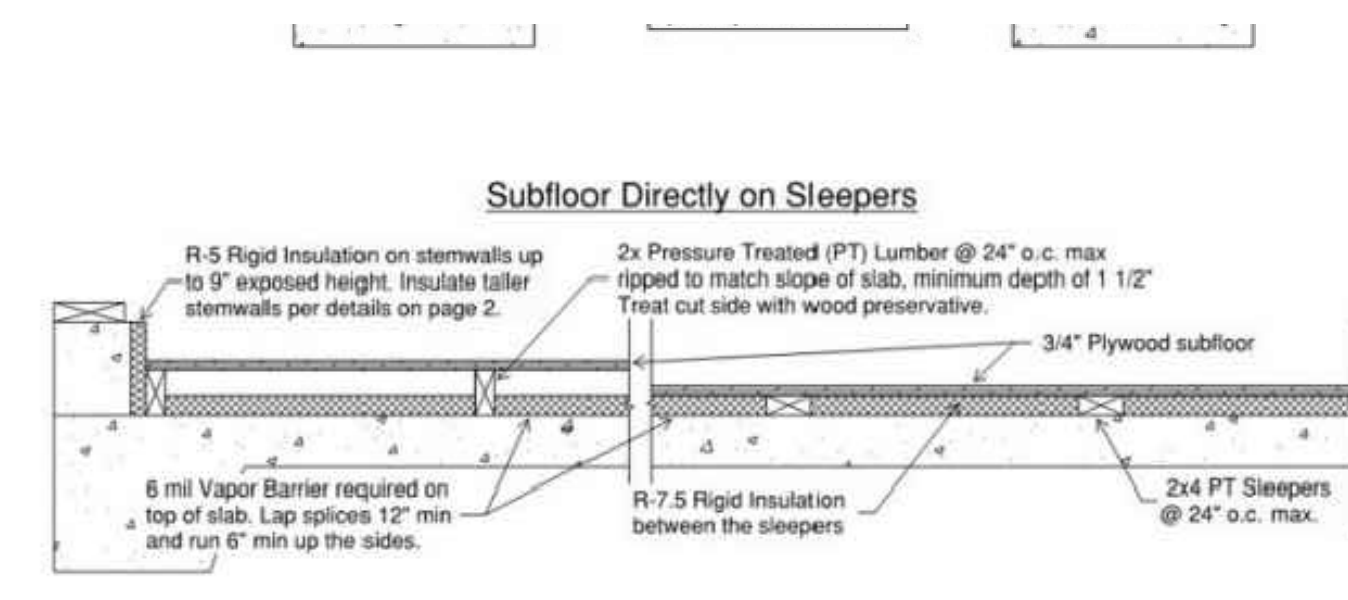

**5** TYP SHEET DETAILS  
APPROVED INSULATION OPTIONS ABOVE THE SLAB

DESIGNER

REVISIONS

NO.	ISSUE	DATE
3		02/15/22

OWNER / LANDLORD  
Victor Lopez  
17107 36th Ave W,  
Lynnwood, WA 98037

CONSULTANTS  
DESIGNER  
EZ PERMITTING  
Esteban Regla  
1530 S Dash Point Rd, Federal  
Way WA 98003  
(562)390-50-46

PROJECT NAME  
**CONVERT GARAGE IN NEW ATTACHED ADU**

PROJECT ADDRESS  
17107 36th Ave W,  
Lynnwood, WA 98037

TITLE  
**PROPOSED FLOOR PLAN**

PROJECT  
SCALE  
DRAWN BY  
DATE  
March 04, 2023

SHEET NUMBER  
**A-2.2**



